

Development of an Ultrasonic Measuring Instrument in the Oil Industry

Tural Kishizada*, Elchin Hasanov

Department of Physics and Electronics of Khazar University

**Corresponding author: tural.kishizada@khazar.org*

Abstract

The article discusses the development of new methods and tools for the use of ultrasonic devices in the oil industry. It should be noted that ultrasonic level measuring devices make it possible for us to measure liquids in tanks up to 5 meters high. Determination of liquid level measurement in different types of tanks can be done using industrial electronics and automation, the principle of operation of such measuring systems is generally the same - one of the main differences when entering information from a measuring sensor into a data processing device based on optical computers is the choice of sensor type. stops. The article analyzes the main technical characteristics of the ultrasonic sensor used in the devices to measure the filling level of the reservoirs. The principles of processor selection are shown. Thus, the article will be about the development of an ultrasonic device.

Introduction

PIC microcontrollers include a RISC-processor with a symmetrical command system that allows you to perform operations with any register using the free method of addressing (Evtikheev, et al. 1990). This microcontroller is able to store the results of the operation in the Register-accumulator itself or in the second register used for the operation. High-speed execution of commands on PIC microcontrollers is achieved through the use of Horvart architecture instead of the traditional Fonneyman technique (Salamova & Binnatov, 2017).

Harvard architecture is based on stacking registers with address fields and tires for command and information (Evstifeev, 2005; Ivanov et al., 2009; Ivanov et al., 2004). The input of the microcontroller (all resources, means, reserves, such as the output portal, memory window and timer) consists of physically implemented hardware registers. Let's choose microcontrollers from PIC18FXXX series.

PIC18FXXX is a family of high-efficiency microcontrollers with a wide command system (75 commands) and a 10-degree analog-to-digital converter (ADC) operating at frequencies up to 40 MHz. They have the ability to address up to 32 words of code and 4 Kbytes of data memory installed in the 31-level hardware memory command, and up to 2 MB of external memory software. The extensive RISC core of the microcontrollers from that family has been optimized for use with the new C compiler. When designing the device, PIC 18F252 28-output high-speed FLASH microcontrollers are grade 10 ADC (Farzana et al., 2000).

Results

The output information signal of the sensor is a constant voltage $+ 0 \div 10V$, the maximum input voltage is equal to the supply voltage (V_n) of the controller АЦП ОЭБМ PIC18F252, it means 5V. Thus, the task of the input converter is to reduce the output voltage (V_a) of the sensor by a factor of two.

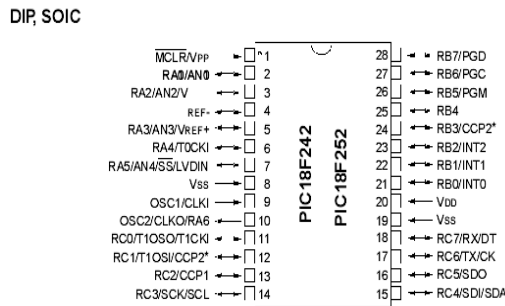

Figure 1. Location of microcontroller outputs

1	MCLR/Vpp	MCS	28	RB7/PGD
2	RA0/AN0		27	RB6/PGC
3	RA1/AN1		26	RB5/PGM
4	RA1/AN2/Vref-		25	RB4
5	RA3/AN3/Vref+		24	RB3/CCP2
6	RA4/T0CKI		23	RB2/INT2
7	RA5/AN4/SS		22	RB1/INT1
8	Vss		21	RB0/INT0
9	OSC1/CLKI		20	Vdd
10	OSC2/CLKO/RA6		19	Vss
11	RC0/T1OSO/T1CKI		18	RC7/RX/DT
12	RC1/T1OSI/CCP2*		17	RC6/TX/CK
13	RC2/CCP1		16	RC5/SDO
14	RC3/SCK/SCL		15	RC4/SDI/SDA

Figure 2. Conventional geographical indication PIC18F252

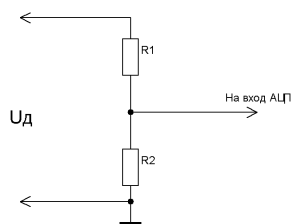

Figure 3. Schematic of the input changer

From the expressions (3.1) and (3.2) we find the nominals of resistors R1 and R2.

$$V_{\text{out}} = 2M_{\text{ADC}} \quad (3.1)$$

$$(R1 + R2) \cdot I = 2 \cdot R2 \cdot I \rightarrow R1 + R2 = 2 \cdot R2 \rightarrow R1 = R2 \quad (3.2)$$

Let's choose the nominals of resistors R1 and R2 at 100 kOhm. In this circuit, it is necessary to use the most accurate dividing resistors of the type C5-53Φ-0.125-100kOhm ± 0.05% to ensure the accuracy of the converter.

The indication block should provide information on the level of filling of the tanks in the form of decimal digits in the format X, XX meters. Thus, as can be seen from the problem, it is important to use an indicator consisting of three LED seven-segment dot indicators. The indication is dynamic.

The A-H segments of the LED seven-segment indicators are connected to the outputs of the microcontroller post RB7-RBO B, respectively, and the indicators are transmitted to the ports that serve the display and are packaged in BCD format. To implement the circuit of the indication block, select the seven-segment LED indicators with red light emission ALC333A. The choice of LED indicators is due to the fact that they have a number of advantages over liquid crystal and vacuum luminescences - a good degree of visibility of indicators at a considerable distance and in the dark. This shows that liquid crystal indicators, as well as indicators with lower energy consumption, are not able to meet the expected potential, unlike vacuum luminescence indicators. ALC333A height is 12 mm, current consumption of each segment is $I_{cs} = 20\text{mA}$, supply voltage is $V_{qg} = 2\text{V}$. The ports of the PIC18F252 microcontroller have a large enough load capacity, so the segments of the indicators are connected directly to the MK outputs without any amplifying elements. Resistors R5-R13 give the required $V_{qg} = 2\text{V}$ for each segment. VII-VT3 bipolar transistors are used as switches from the RCO-RCO2 ports to select a specific indicator with a control signal, thus fulfilling the dynamic mode of

indication. We choose KT814A transistors to implement the circuit. We choose resistors R5-R13. The denominations of resistors R5-R13 are calculated as follows (Figure 3):

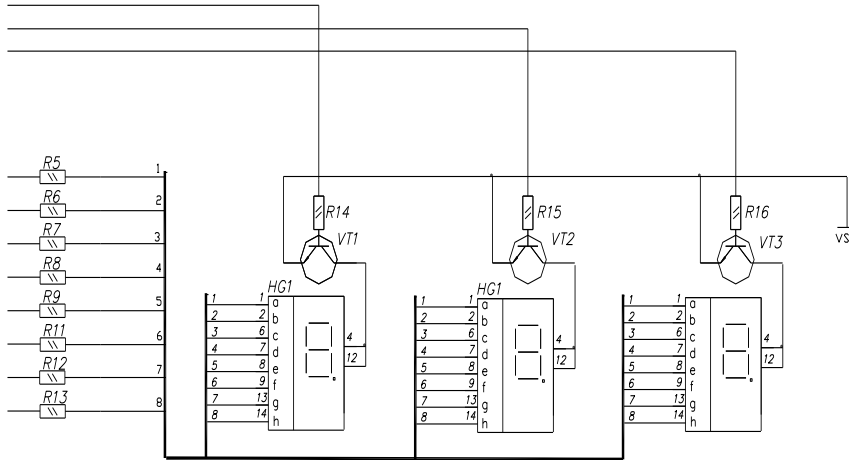

Figure 3. Schematic of the indication block

$$V_R = U_{MKout} - V_{ke} - V_{vd}, \quad (3.3)$$

Here,

Log unit voltage at U_{MKout} -MK outputs, voltage drop in V_R -resistor, voltage drop in V_{vd} indicator segment.

Considering the value of $V_R = 1V$

$$R = \frac{V_R}{I_{cs}} \quad (3.4)$$

Where I_{cs} is the voltage dissipated by the segment of the indicator. Thus $R = 50$ Ohm. C2-33-0,125-50 Ohm $\pm 1\%$ resistor is selected.

R14-R16 resistors in the base circuits of transistor switches are distinguished by a nominal value of 470 Ohm, type: C2-33-0,125-470 Ohm $\pm 1\%$.

Then the parameters to be selected by the keyboard, communication unit and, finally, the process of calculating the power supply are taken into account, and thus the selection of RISC-processor components with a symmetrical command system that allows to perform operations for the operation of ultrasonic devices is considered complete.

References

- Evstifeev, A.V.** (2005). Tiny and Mega family AVR microcontrollers from ATMEL. 2nd edition. M.: Dodeka-XXI.
- Evtikheev, N.N., Skugorov, V.N., & Papulovsky, V.F.** (1990). Measurement of electrical and non-electric quantities (textbook for universities). M., Energoatomizdat, 349 p.
- Ivanov, Yu.I. & Yugai, V.Ya.** (2009). Microprocessor technology in control systems. Part II: Tutorial. - Taganrog: TTI SFU Publishing House.
- Ivanov, Yu.I. & Yugai, V.Ya.** (2004). Microprocessor devices of control systems: Methodological guide to laboratory work. - Taganrog: Publishing House of TRTU.
- Farzana N.H.** (2005). Technological measurements and devices (textbook). Baku, ADNA, 310 s.
- Farzanə N.H., Jəfərov H.C., & Abbasova S.M.** (2000). Basics of metrology. Baku, ADNA, 212 s.
- Klassen, K.B.** (2000). Fundamentals of measurements. Electronic methods and devices in measuring technology. M., Postmarket, 352 p.
- Mammədov R.Q., Tagiyev F.K., Mutallimova A.S.** (2013). Basics of measurement techniques. Baku, ADNA, -250 s.
- Salamova Kh.E., & Binnatov M.F.** (2017). Materials of the Republican Scientific-Technical Conference on "Youth and Scientific Innovations", Baku, AzTU, 82-184.